

eCobra 600 Lite/Standard/Pro

Mid-size SCARA robot for precision machining, assembly, and material handling

- Ethernet capability to control the robot through the familiar programming language (IEC 61131-3) of Machine Automation Controller NJ/NX/NY Series
- High repeatability suitable for material handling and precision assembly
- High payload for screw-driving tools
- Amplifier and controller built into the robot reduces the number of cables
- Choose the right robot for you application from three different types
- Reach 600 mm
- Maximum payload 5.5 kg
- Weight 41 kg

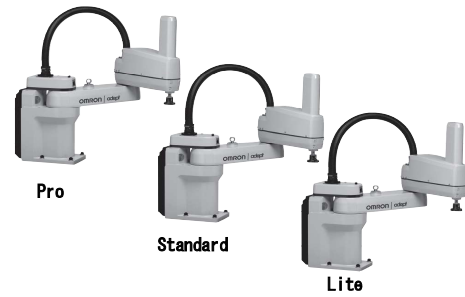

Specifications

Product name		eCobra					
		600					
		600 Lite		600 Standard		600 Pro	
Size		Standard	Cleanroom	Standard	Cleanroom	Standard	Cleanroom
Type							
Cleanroom							
Part Number		17010-16000	17010-16010	1711[]-16000	1711[]-16010	1721[]-16000	1721[]-16010
Number of axes		4					
Mounting		table/floor					
Reach		600 mm					
Maximum Payload		5.5 kg					
Repeatability	XY	±0.017 mm					
	Z	±0.003 mm					
	Theta	±0.019°					
Joint Range	Joint 1	±105°					
	Joint 2	±157.5°					
	Joint 3	210 mm					
	Joint 4	±360°					
Inertia Moment (Max.)	Joint 4	450 kg-cm ²					
Joint Speeds	Joint 1	386°/s					
	Joint 2	720°/s					
	Joint 3	1100 mm/s					
	Joint 4	1200°/s					
Cycle times *1 (Payload 2.0 kg)	Burst	0,66 s		0,55 s		0,39 s	
	Sustained	0,66 s		0,55 s		0,45 s	
Power Requirements		24 VDC: 6 A 200 to 240 VAC: 10 A, single-phase					
Protection		IP20					
Clean Class		---	Class 10	---	Class 10	---	Class 10
Environment Requirements	Ambient Temperature	5 to 40°C					
	Humidity Range	5 to 90% (non-condensing)					
Weight		41 kg					
Basic configuration	Controller	eAIB					
	On-board I/O (Input/Output)	12/8, 4 Solenoid Output					
	Conveyor tracking input	No				2	
	RS-232C serial communications port	No		1			
	Programming environment	ACE		ACE, PackXpert, ePLC			
	ACE Sight	No *2		Yes			
	ePLC Connect	No		Yes			
ePLC I/O	No				Yes		
Connectable controller *3		No		SmartController EX, NJ/NX/NY Series *4			

*1. Adept cycle, in mm 25/305/25 (seconds, at 20°C ambient)

*2. The SmartVision MX cannot be used with the Lite type.

*3. Choose a controller to suit your application.

*4. The robot version 2.3.C or later is required to connect with the NJ/NX/NY Series.

Dimensions

(Unit: mm)

eCobra 600

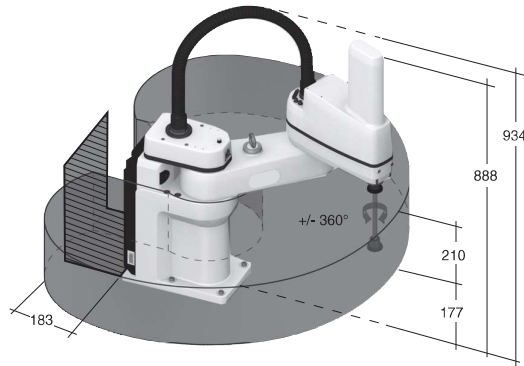

- Work Envelope: Radius 600 mm
Inner Limit: Radius 163 mm
Height: 210 mm
- ▨ Required clearance to open eAIB Chassis

Flange

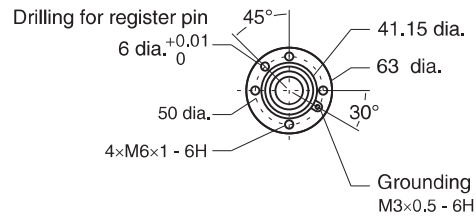

Footprint

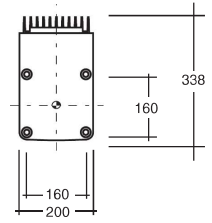

Front panel

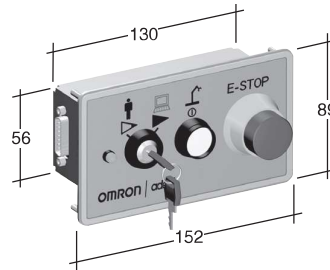

Robot Parts Code and Bundled Accessories

Type	eCobra		eCobra Add-On	
	Cleanroom	Standard	Cleanroom	Standard
eCobra 600 Lite	17010-16000	17010-16010	---	---
eCobra 600 Standard	17111-16000	17111-16010	17113-16000	17113-16010
eCobra 600 Pro	17211-16000	17211-16010	17213-16000	17213-16010
Overview	Robot + eAIB with fully integrated controls		Robot + eAIB with required connection cables	
Purpose	Typical for use in single robot system		Typically added to systems with an existing SmartController EX to create multi-robot systems	
Bundled Accessories	<ul style="list-style-type: none"> • XSYSTEM cable with jumpers, 1.8 m/6 ft (13323-000) • Front panel kit (90356-10358) 		<ul style="list-style-type: none"> • XSYSTEM cable with jumpers, 1.8 m/6 ft (13323-000) • XSYS cable, 4.5 m/15 ft (11585-000) • DB9 splitter (00411-000) • 1394 latch cable, 4.5 m/15 ft (13632-045) • eV+ license to connect to controller (14529-103) 	